

P.C.B LAYOUT(±0.1)
(BOTTOM VIEW)

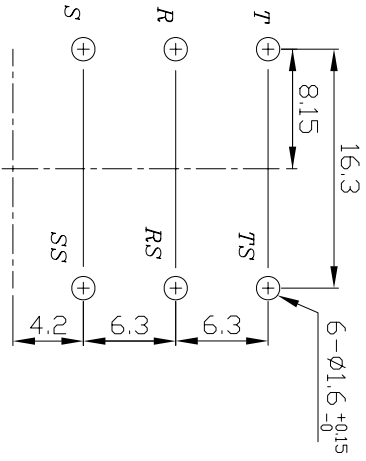

| | | | | | | |
|----|--------------|------|-------------|----------------------|-----------------|--|
| 5 | WASHER | 1 | PARER SHEET | | RED(Fittings) | |
| 4 | NUT | 1 | PA66 | | BLACK(Fittings) | |
| 3 | HOUSING | 1 | PA66 | | BLACK | |
| 2 | TIP SPRING | 3 | P.B.S | (Ni/Ag) | | |
| 1 | SHUNT SPRING | 3 | BRASS | (Ni/Ag) | | |
| NO | PART NAME | Q'TY | MATERIAL | PLATED | REMARK | |

| | | | | |
|-----------|-------|-----------|-----------|----------------|
| TOLERANCE | | Material | PART NAME | HEADPHONE JACK |
| X | ±0.5 | Thickness | PART NO. | LJB0661-6 |
| X.X | ±0.3 | Disposal | DATE | 11/10/88' |
| X.XX | ±0.15 | UNIT | SCALE | 2:1 |
| | | | DRAW | Vicky |
| | | | CHECK | Chris |
| | | | APPROVED | Ken |

LIH SHENG PRECISION INDUSTRIAL CO., LTD.

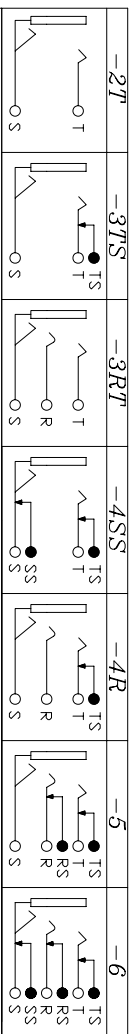

| | | | | | |
|---------|-----------|--------|------|----------|-------|
| HISTORY | DATE | ECONO. | REV. | REVISION | SIGN. |
| X/COUNT | 29/DEC/08 | | A | 圖面重繪 | Chris |

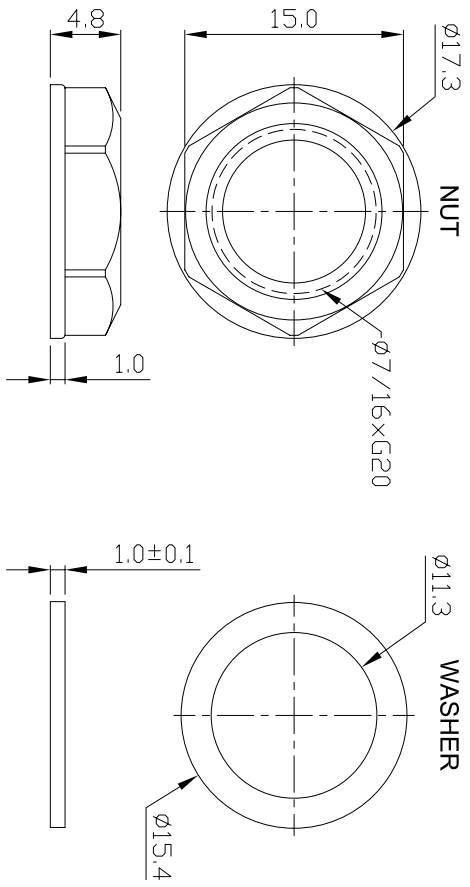
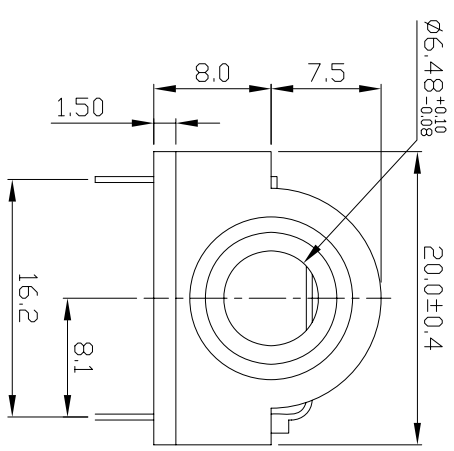
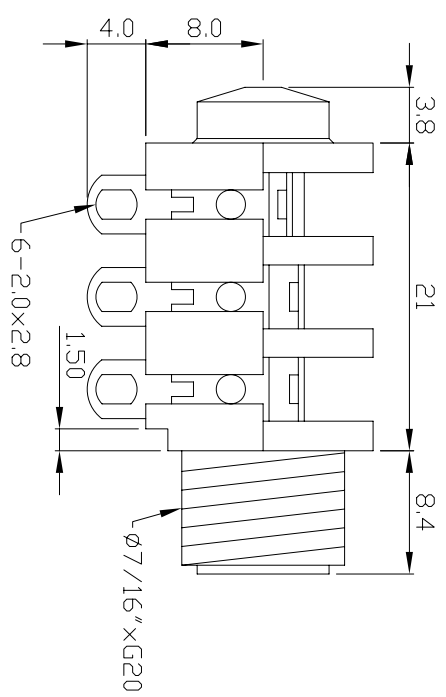

| | | | | | |
|----|--------------|-----|---------------|-----------------|--------|
| 5 | WASHER | 1 | PARER SHEET | RED<fittings> | |
| 4 | NUT | 1 | PA66 | BLACK<fittings> | |
| 3 | HOUSING | 1 | NYLON-66 94V2 | BLACK | |
| 2 | TIP SPRING | 3 | P.B.S | (NI/Ag) | |
| 1 | SHUNT SPRING | 3 | BRASS | (NI/Ag) | |
| NO | PART NAME | QTY | MATERIAL | PLATED | REMARK |

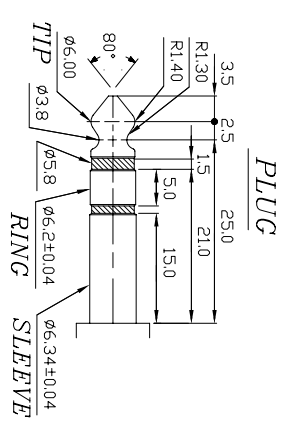
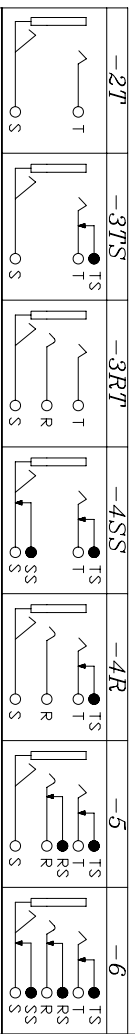

LIH SHENG PRECISION INDUSTRIAL CO., LTD.

| | | | | | |
|-----------|------------|-----------|----------|----------------|----------|
| TOLERANCE | | PART NAME | | HEADPHONE JACK | |
| X | ± 0.5 | Material | PART NO. | LJB0661A-6 | REV.A |
| X.X | ± 0.3 | Thickness | DATE | 11/10/88 | CHECK |
| X.XX | ± 0.15 | Disposal | DRAW | Chris | APPROVED |
| | | UNIT | SCALE | 2:1 | Ken |
| | | | | | Ken |

| | | | | | |
|---------|-----------|----------|------|----------|-------|
| HISTORY | DATE | ECON NO. | REV. | REVISION | SIGN. |
| X COUNT | 31/DEC/08 | | A | 圖面重繪 | Chris |

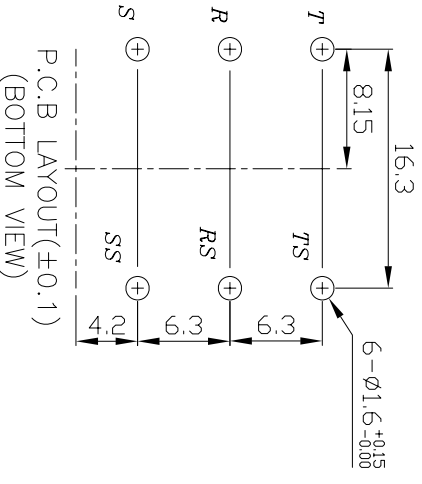
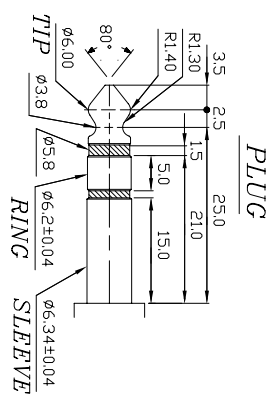
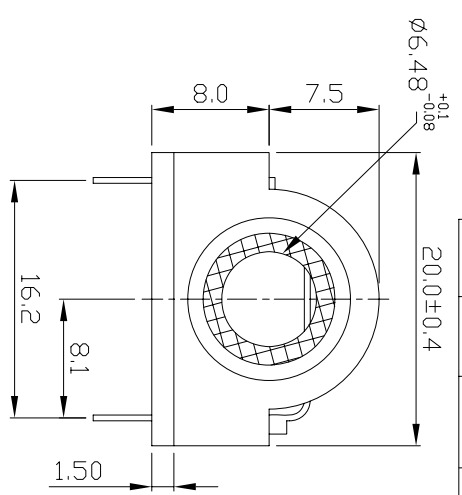
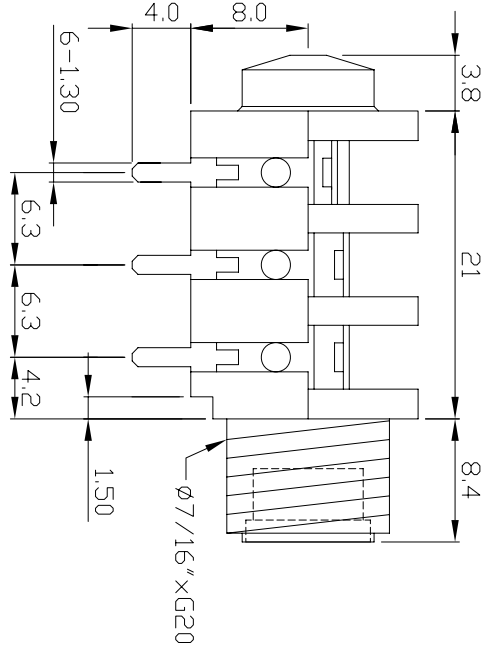

| | | | | | | |
|----|--------------|-----|-------------|--------|------------------|--|
| 6 | WASHER | 1 | PAPER SHEET | | RED (Fittings) | |
| 5 | NUT-HEXAGON | 1 | PA66 | | BLACK (Fittings) | |
| 4 | HOUSING | 1 | PA66 | | BLACK | |
| 3 | METAL RING A | 1 | BRASS | | NICKEL | |
| 2 | TIP SPRING | 3 | P.B.S | | (NI/Ag) | |
| 1 | SHUNT SPRING | 3 | BRASS | | (NI/Ag) | |
| NO | PART NAME | QTY | MATERIAL | PLATED | REMARK | |

| | | | | | |
|------------------------------------------------------|--|------------------------------------------------|--|-------------------------------------------------------|--|
| | | LH SHENG PRECISION INDUSTRIAL CO., LTD. | | HEADPHONE JACK | |
| TOLERANCE X ±0.5 X.X ±0.3 X.XX ±0.15 | | Material Thickness Disposal | | PART NAME PART NO. DATE DRAW Chris | |
| | | UNIT mm | | SCALE 2:1 | |
| | | | | CHECK Ken | |
| | | | | APPROVED Cooper | |

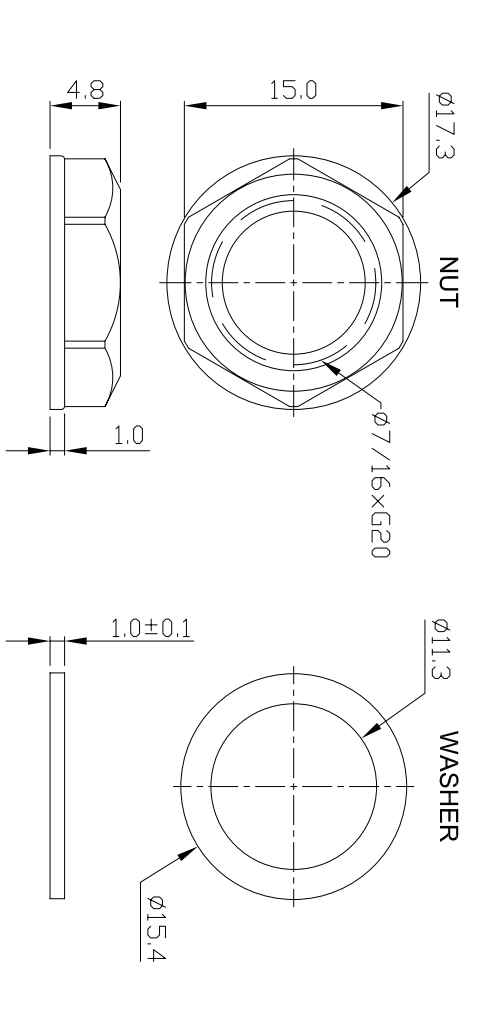

| | | | | | |
|---------|-----------|----------|------|--------------------------|-------|
| HISTORY | DATE | ECON NO. | REV. | REVISION | SIGN. |
| X/COUNT | 06/16/06 | | B | 圖面更新・BUSHING改爲METAL RING | CHRIS |
| x1 | 13/JAN/09 | | C | 圖面重繪。 | CHRIS |

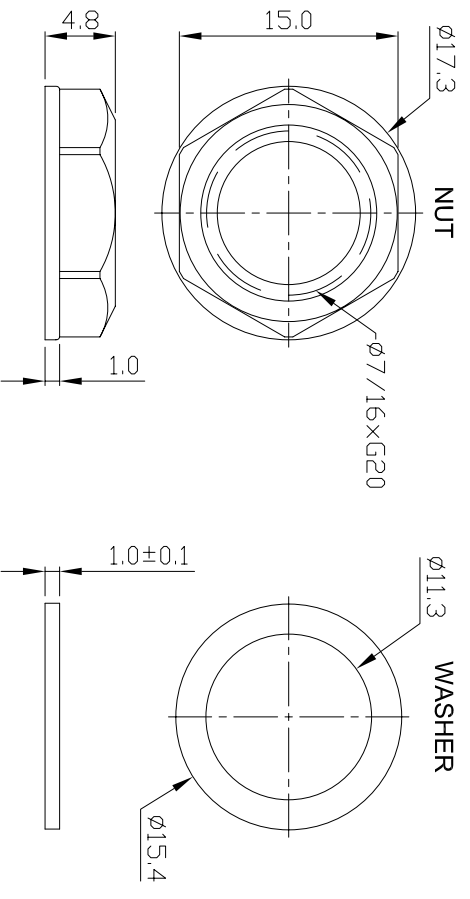
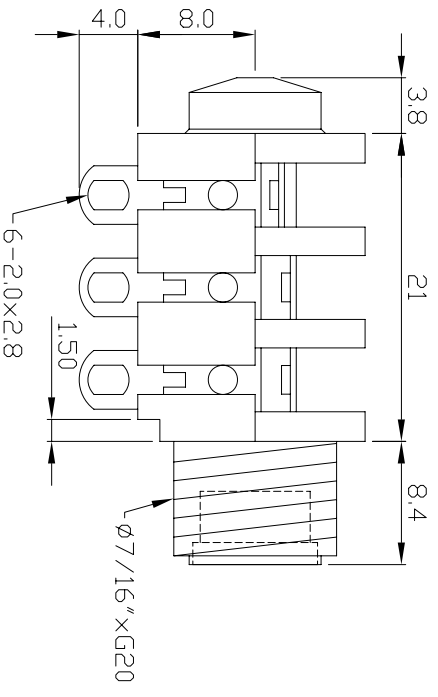

| | | | | | |
|----|---------------------|-----|-------------|--------|-------------------|
| 6 | WASHER | 1 | PAPER SHEET | | |
| 5 | NUT-HEXAGON | 1 | PA66 | | RED (Fittings) |
| 4 | HOUSING | 1 | PA66 | | BLACK (Fittings) |
| 3 | METAL RING Δ | 1 | BRASS | | BLACK |
| 2 | TIP SPRING | 3 | P.B.S | | NICKEL (NI/AG) |
| 1 | SHUNT SPRING | 3 | BRASS | | (NI/AG) |
| NO | PART NAME | QTY | MATERIAL | PLATED | REMARK |

| | | | | | |
|--------------------|------------|-----------|------|----------------------------|-------|
| HISTORY X/COUNT | DATE | ECON. NO. | REV. | REVISION | SIGN. |
| Δ x1 | 06/23/06' | | B | 圖面更新・BUSHING 改爲 METAL RING | CHRIS |
| Δ x1 | 13/JAN/09' | | C | 圖面重繪。 | CHRIS |

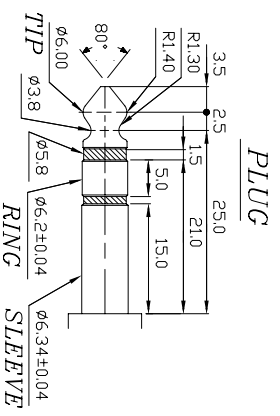
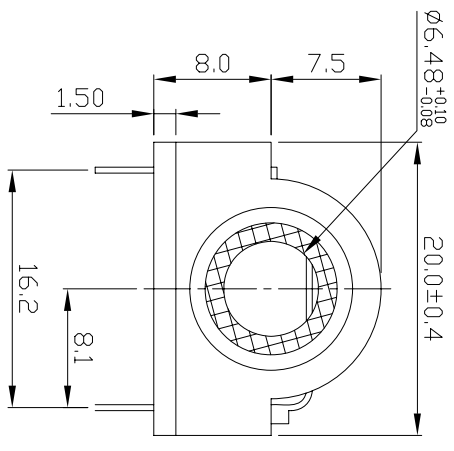

| | | | | | | |
|-----|------|------|------|-----|----|----|
| -2T | -3TS | -3RT | -4SS | -4R | -5 | -6 |
| | | | | | | |



LIH SHENG PRECISION
INDUSTRIAL CO., LTD.

| | | | |
|-----------------|-----------|-----------|----------------|
| TOLERANCE | Material | PART NAME | HEADPHONE JACK |
| X. ± 0.5 | Thickness | PART NO. | LJB0661BA-6 |
| X.X ± 0.3 | Disposal | DATE | 11/10/88' |
| X.XX ± 0.15 | UNIT | SCALE | 2:1 |
| | mm | DRAW | Ken |
| | | CHECK | Ken |
| | | APPROVED | Ken |

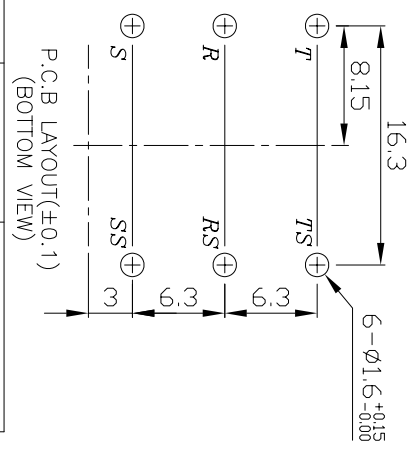
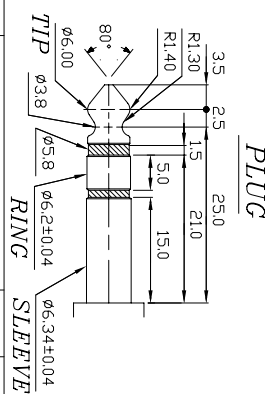
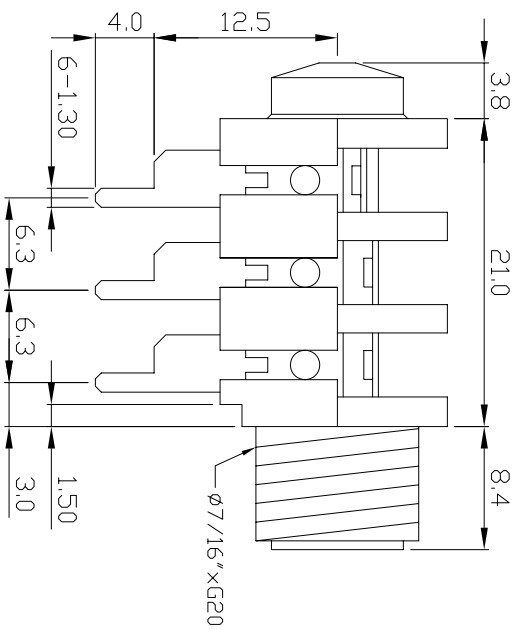

| | | | | | |
|----|--------------|-----|-------------|------------------------------------|-----------------|
| 5 | WASHER | 1 | PARER SHEET | | RED(Fittings) |
| 4 | NUT | 1 | PA66 | | BLACK(Fittings) |
| 3 | HOUSING | 1 | PA66 | | BLACK |
| 2 | TTP SPRING | 3 | P.B.S | $\langle NI/Ag \rangle$ | |
| 1 | SHUNT SPRING | 3 | BRASS | $\langle NI/Ag \rangle$ | |
| NO | PART NAME | QTY | MATERIAL | PLATED | REMARK |

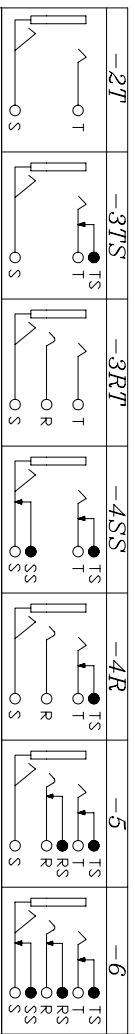
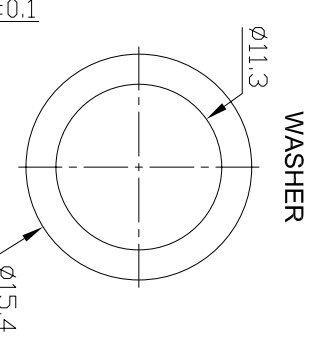
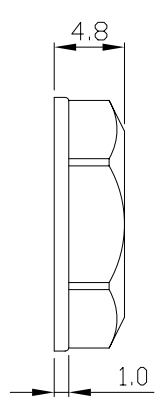
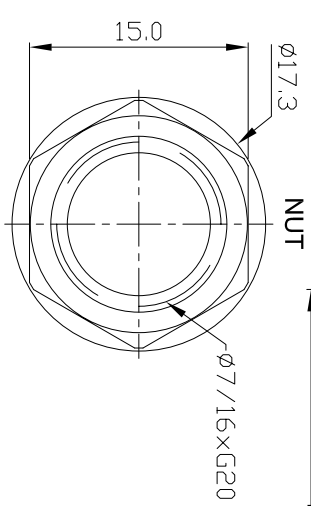
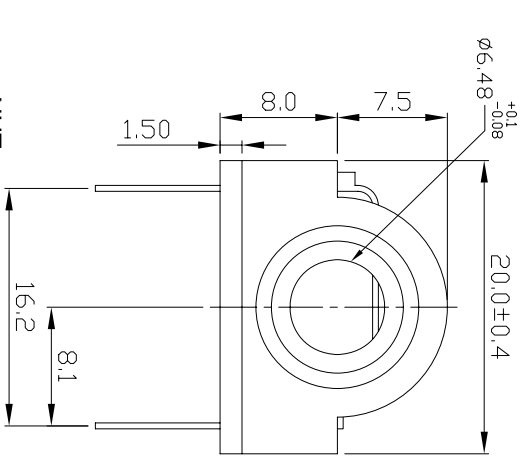

LIH SHENG PRECISION INDUSTRIAL CO., LTD.

| | | | | | |
|-----------|-------|----------------|--|------------|--|
| TOLERANCE | | Material | | PART NAME | |
| X | ±0.5 | HEADPHONE JACK | | LJB0661L-6 | |
| X.X | ±0.3 | Thickness | | PART NO. | |
| X.XX | ±0.15 | Disposal | | DATE | |
| | | UNIT | | DRAW | |
| | | SCALE | | Chris | |
| | | 2:1 | | Ken | |
| | | REV. A | | APPROVED | |
| | | Cooper | | | |

| | | | | | |
|---------|-----------|----------|------|----------|-------|
| HISTORY | DATE | ECON NO. | REV. | REVISION | SIGN. |
| X COUNT | 19/JAN/09 | | A | 圖面重繪 | Chris |